

METAL SEAL CONNECTOR FOR CLADDED PIPELINES

A VERSATILE DIVER/DIVERLESS MECHANICAL CONNECTOR
FOR THE REPAIR OF SUBSEA CLADDED AND SOUR SERVICE PIPELINES

METAL SEAL CONNECTOR FOR CLADDED PIPELINES

A VERSATILE DIVER/DIVERLESS MECHANICAL CONNECTOR FOR THE REPAIR OF SUBSEA CLADDED AND SOUR SERVICE PIPELINES

FUNCTIONAL DESCRIPTION

The MSC features a front metal seal of new concept capable of sealing against the internal CRA layer of the cladded pipeline, while adapting to the pipe cut end and managing the pipeline tolerances and out of roundness. The MSC is mechanically connected to the pipeline by means of a gripping system with teeth which are outboard of the metal seal and not in contact with the pipeline's corrosive fluid.

This gripping system has the purpose of transferring all loads (axial, bending and torsion) from the pipeline to the connector flange and of locking the seal against the pipe end. The connector is capable of withstanding full pipeline pressure, axial and bending loads ("stronger than the pipe") and also the external environment hydrostatic pressure, such as in the case of a pipeline dewatering scenario.

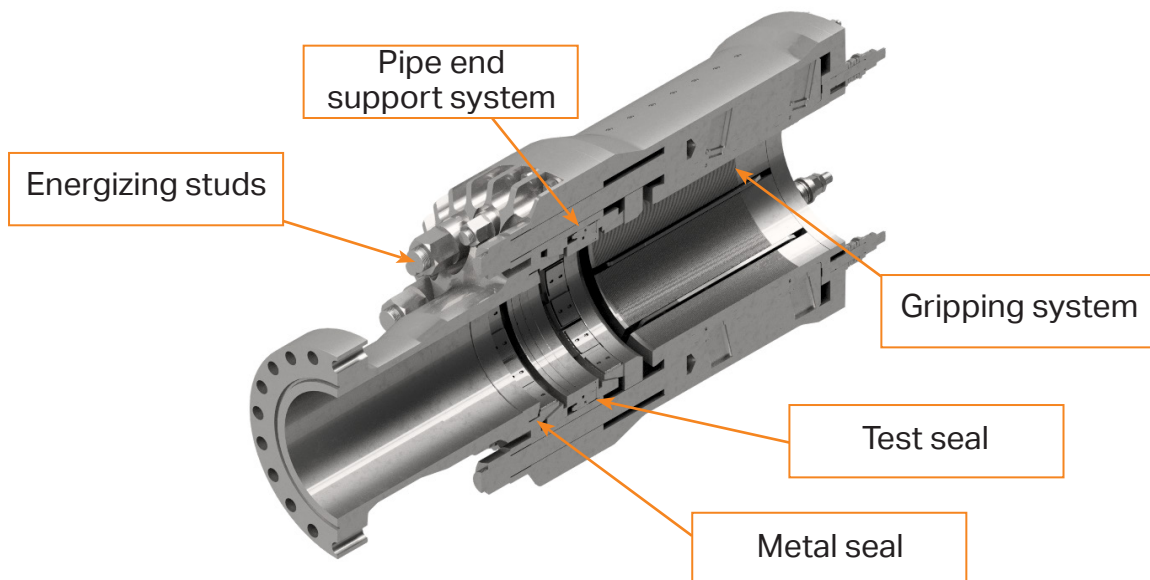

Metal Seal Connector: section and details

All the actuations for connecting the MSC to the pipeline and for seal energization are, as base case, hydraulically operated by means of subsea tensioners operable by divers and are reversible to allow removal of the connector from the pipeline if required.

Optionally, the MSC actuation can be achieved by means of specially designed torque

wrenches for diverless applications.

The connector end flange can be adapted according to client requirements, alternatively a proprietary flange design can be adopted together with a diverless flange make-up system for a fully diverless application.

As a base case, Saipem proposes a Vector SPO Compact weldneck flange.

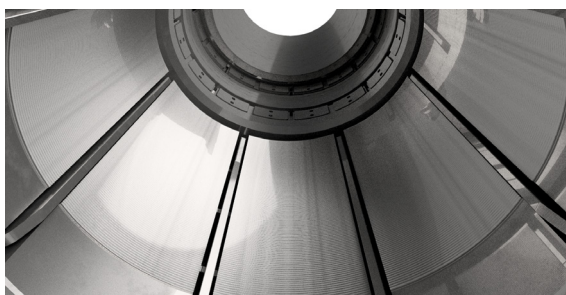

Gripping elements



Metal seal

KEY FEATURES AND BENEFITS

The MSC offers a metal-to-metal permanent sealing within a lightweight design (**up to 40% lighter than other connectors** on the market). Above all, the MSC connection to the pipe cut face doesn't affect the internal diameter of the pipe, since **no ID reduction** is caused by applying the connector.

Additionally, the connector has **a large radial installation gap** while being 100% compliant to pipe tolerances according to DNV codes and **removal of the longitudinal weld seam is not required**, thus simplifying the installation process. These are **unparalleled characteristics, not available via any other commercial product**.

The connector design is also capable of managing pipelines with multiple wall thicknesses and, if required, internal interchangeable kits can be provided for the sealing and gripping elements to cover the whole wall thickness range. These features grant easiness of installation and **permanent repairs** even with highly corrosive fluids and clad pipes. Another unique feature is that the connector is fully compliant with the most recent applicable codes, i.e. DNV-RP-F113 "pipeline subsea repair" and DNV-ST-F101 "submarine pipeline systems", and will be soon covered by a DNV Type Approval Certificate.

APPLICABLE SCENARIOS AND SEAL MECHANISM

The MSC has been specifically developed for clad pipelines with highly corrosive fluids and can be used also on lined pipes; nevertheless, with minor differences in the sealing configuration the connector is also applicable to pipelines with sweet service or sour service with a corrosion allowance, in the latter case by managing the reduction of pipe wall thickness over the residual pipe design life.

Depending on the actual pipeline scenario, the pipe end will be adequately prepared after

cutting for mating with the specific seal design. For clad pipelines, the pipe end machining and seal geometry will ensure that the metal seal will come into contact with the cladding layer first so that during seal energization, the cladded thickness will be deformed first. The sealing will then be achieved between the seal and the cladding; eventually also part of the pipeline base metal will be deformed first against the seal to provide support and to withstand all pipeline loading scenarios.

OUTLINE INSTALLATION METHOD

The installation procedure includes the following steps:

- Pipeline cutting (e.g. by means of diamond wire cutting tool or similar);
- Removal of external anti-corrosion coating (and concrete weight coating, if any), up to bare steel, for the full length of the repair connector;
- Pipe end face preparation;
- Connector insertion onto the pipe cut end, until abutment is achieved;
- Activation of the gripping and pipe end support systems for centering of the connector on the pipe, recovery of out of roundness and seal energization;
- Test seal energization and back seal test (if required to verify correctness of installation);
- Repair operations are then completed by installing the second connector as above and performing the tie-in of a properly designed repair spool.

SAIPEM PATENTED DESIGN - KEY SPECIFICATIONS

**from
6" to 38"**
NOMINAL PIPE SIZE

30 years
DESIGN LIFE

**up to
2,000 m**
WATER DEPTH

**-20 °C
to 105 °C**
DESIGN TEMPERATURE

up to 650 bar
PIPELINE DESIGN PRESSURE
RATING FOR SMALLER SIZES

up to 360 bar
PIPELINE DESIGN PRESSURE
RATING FOR LARGER SIZES



SAIPEM SpA

Via Martiri di Cefalonia, 67
20097 San Donato Milanese
Milan - Italy

SAIPEM.COM

For info please contact:
+39 041 9650 311

LET'S KEEP IN TOUCH

